

# ZD

VENTILATORI DA TRASPORTO  
BLOWER FOR MATERIAL TRANSPORTING

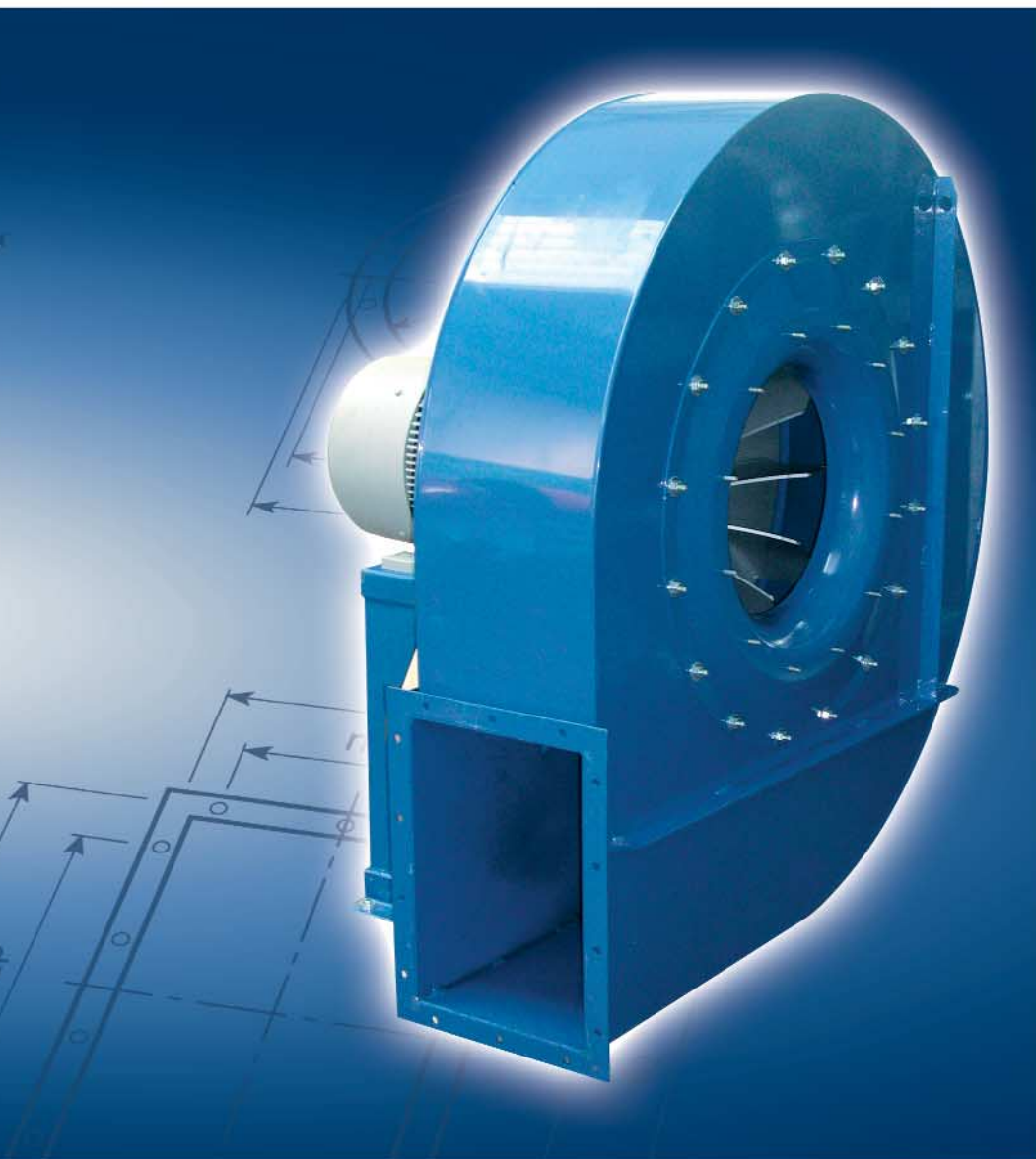

GIRANTE A PALE APERTE AVANTI  
FORWARD OPEN BLADES IMPELLER



MEDIA PRESSIONE  
MEDIUM PRESSURE

Portata/Flow rate:  
3000 ÷ 19000 m<sup>3</sup>/h

Pressione/Pressure:  
160 ÷ 330 mm H<sub>2</sub>O





# ZD

## VENTILATORI DA TRASPORTO BLOWER FOR MATERIAL TRANSPORTING



### **Ventilatore ad alto rendimento: Mod. ZD.**

Campo di lavoro: portate piccole, prevalenze medio alte.

Tipo di pale: aperte.

Applicazioni: per trasporto pneumatico, di materiali solidi in miscela con aria, segatura e trucioli di legno; anche per materiali filamentosi che ostruirebbero una ventola a pale rovesce.

Temperatura del fluido: fino a 60° C in esecuzione standard; esecuzioni speciali per temperature superiori.

Caratteristiche costruttive: ventilatore di costruzione particolarmente robusta eseguito in lamiera verniciata, ventola in acciaio equilibrata staticamente e dinamicamente. Caratteristiche di funzionamento: condizioni dell'aria in aspirazione  $T = 15^{\circ} \text{C}$ ,  $p = 1 \text{ atm}$ .

### **High efficiency fan: Mod. ZD.**

*Field of application: low capacities, high and low pressures.*

*Type of blades: open.*

*Applications: for pneumatic conveyance of solid materials mixed with air, sawdust and woodchips; particularly suitable for fibrous materials that could clog a reverse type impeller of normal construction.*

*Air temperature: up to 60° C standard, special features for higher temperatures.*

*Construction specifications: rigid construction in sheet metal.*

*Statically and dynamically balanced impellers.*

*Working principles: condition of the ducted air  $T = 15^{\circ} \text{C}$ ,  $p = 1 \text{ atm}$ .*

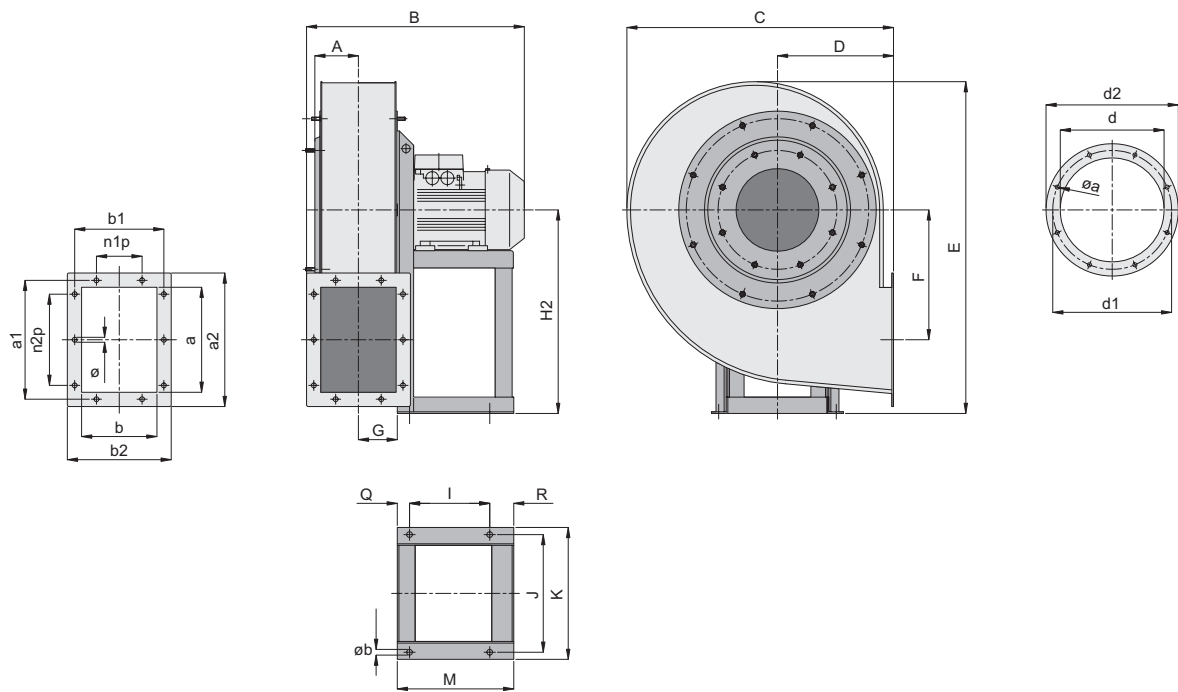

Orientamento RD 270  
Position RD 270

Direzioni di rotazione (vista lato motore) - Rotation senses (seen from motor side)

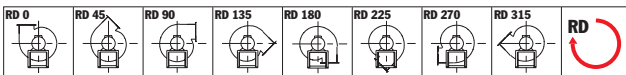

Rotazione oraria - Clockwise rotation sense

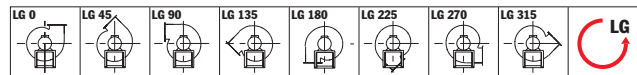

Rotazione anti-oraria - Anti-Clockwise rotation sense

# DIMENSIONI D'INGOMBRO

## OVERALL DIMENSIONS



# ZD 630÷835

Peso ventilatore in Kgf (completo di motore) - Weight of ventilator (complete with motor)  
 Nota: Quota B indicativa - Note: B quote indicative

TIPO - TYPE		kW inst.	PESO WEIGHT	VENTILATORE FAN									
VENTILATORE FAN	MOTORE MOTOR			kgf	A	B	C	D	E	F	G	H	H <sub>1</sub>
<b>ZD 630</b>	<b>112 M4</b>	4	131	127	647	910	425	1000	348	120	560	425	560
<b>ZD 670</b>	<b>132 S4</b>	5,5	170	141	647	1015	475	1122	389	134	630	475	630
<b>ZD 700</b>	<b>132 M4</b>	7,5	180	141	712	1015	475	1122	389	134	630	475	630
<b>ZD 750</b>	<b>160 M4</b>	11	252	163	811	1140	530	1265	440	150	710	530	710
<b>ZD 800</b>	<b>160 L4</b>	15	267	163	851	1140	530	1265	440	150	710	530	710
<b>ZD 835</b>	<b>180 M4</b>	18,5	355	180	969	1285	600	1428	496	167	800	600	800
<b>ZD 835 R</b>	<b>180 L4</b>	22	365										

TIPO - TYPE	FLANGIA ASPIRANTE INLET FLANGE					FLANGIA PREMENTE OUTLET FLANGE										BASAMENTO BASE													
	d	d <sub>1</sub>	d <sub>2</sub>	n°	∅	a	b	a <sub>1</sub>	b <sub>1</sub>	a <sub>2</sub>	b <sub>2</sub>	n <sub>1</sub> xp	n <sub>2</sub> xp	n°	∅	I	J	K	L	M	N	O	P	Q	R	S	T	U	∅
<b>ZD 630</b>	360	405	440	8	12	322	229	366	273	402	309	1x125	2x125	10	12	197	289	324	-	276	-	-	-	30	49	-	-	-	12
<b>ZD 670</b>	405	448	485	12	12	361	256	405	300	441	336	1x125	2x125	10	12	237	337	372	-	336	-	-	-	40	59	-	-	-	12
<b>ZD 700</b>	405	448	485	12	12	361	256	405	300	441	336	1x125	2x125	10	12	237	337	372	-	336	-	-	-	40	59	-	-	-	12
<b>ZD 750</b>	455	497	535	12	12	404	288	448	332	484	368	1x125	3x125	14	12	337	395	440	-	436	-	-	-	50	49	-	-	-	14
<b>ZD 800</b>	455	497	535	12	12	404	288	448	332	484	368	1x125	3x125	14	12	337	395	440	-	436	-	-	-	50	49	-	-	-	14
<b>ZD 835</b>	497	551	585	12	12	453	322	497	366	533	402	1x125	3x125	14	12	357	434	488	-	460	-	-	-	70	33	-	-	-	17
<b>ZD 835 R</b>																													



# CARATTERISTICHE VENTILATORI SERIE "ZD"

## CHARACTERISTICS OF "ZD" SERIES VENTILATORS

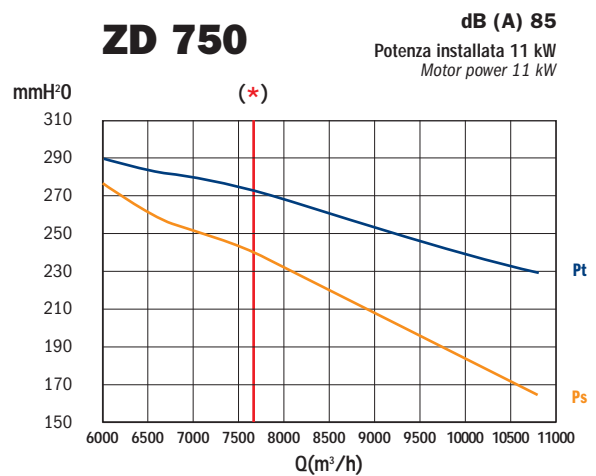
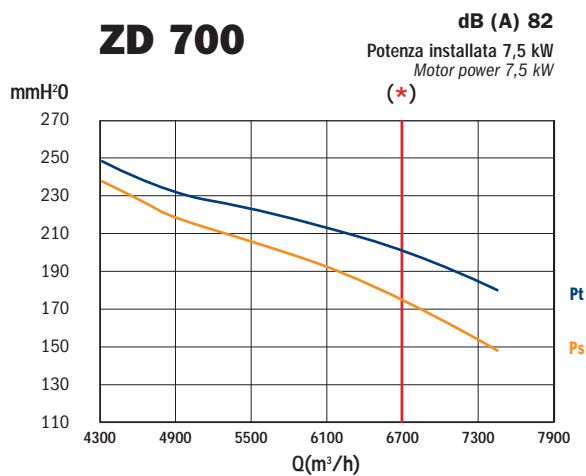
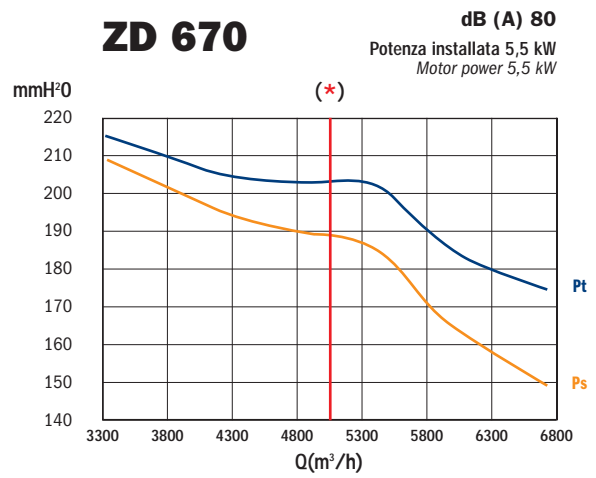
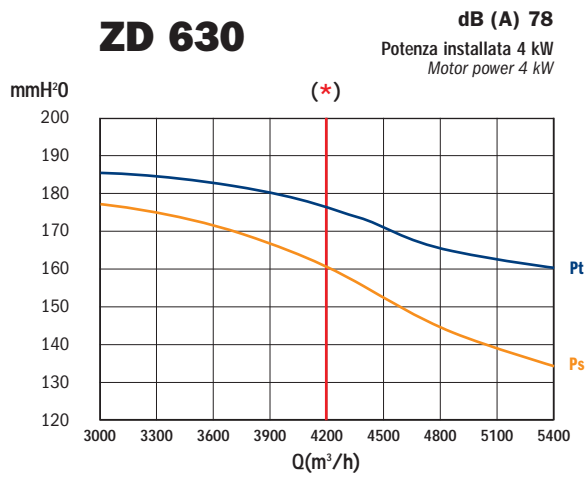

Valori riferiti a: / Datas referring to: T=15°C; P=1 atm

— Pt= Pressione totale - Total pressure    — Ps= Pressione statica - Statical pressure

(\*) Limite di potenza installata Per portate più elevate è necessario installare un motore con potenza maggiorata.  
 Installed power limit. For higher flow rates a more powerful motor is needed.

# CARATTERISTICHE VENTILATORI SERIE "ZD"

## CHARACTERISTICS OF "ZD" SERIES VENTILATORS

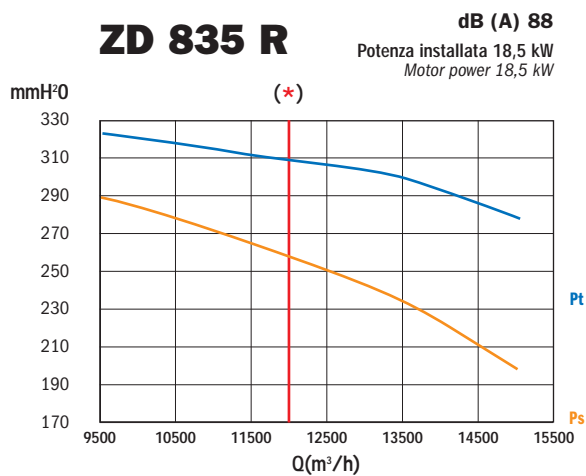
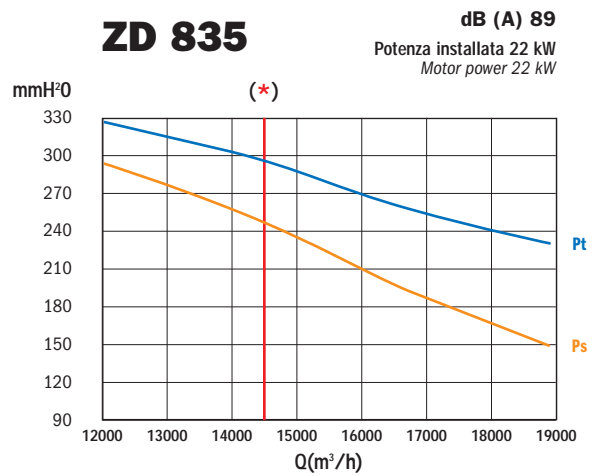
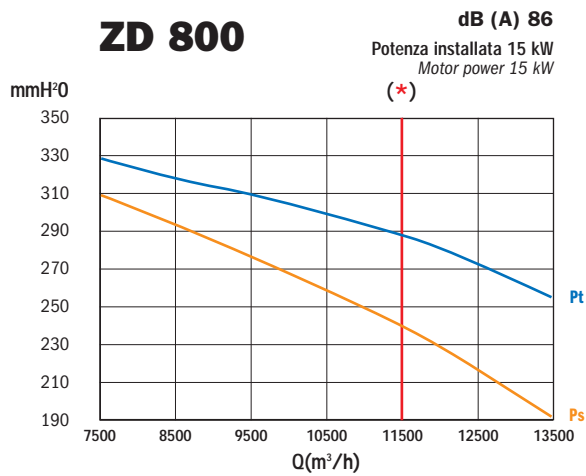

Valori riferiti a: / Datas referring to: T=15°C; P=1 atm

— Pt= Pressione totale - Total pressure    — Ps= Pressione statica - Statical pressure

(\*) Limite di potenza installata Per portate più elevate è necessario installare un motore con potenza maggiorata.  
 Installed power limit. For higher flow rates a more powerful motor is needed.